

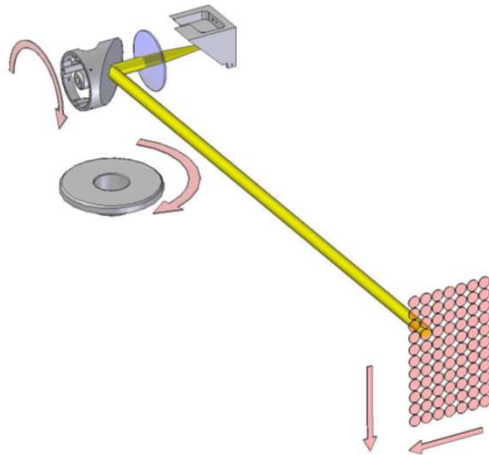

Innovative technology 38 years in the making

## What is LiDAR?



**L**ight

**D**etection

**A**nd

**R**anging

LiDAR is an acronym for measurement technique, using light (typically a laser) to measure distance.

The measurements are typically very fast, generating a 3-dimensional collection of points referred to as a point cloud.

LiDAR has been used for decades but terrestrial units first came onto the market in the mid '90s and entered mainstream use in the last ten years.

The last few years has seen a proliferation of new models and applications.

LiDAR systems are commonly called 3D laser scanners.



Essentially, LiDAR is a form of reality capture, transferring the real world into the digital.

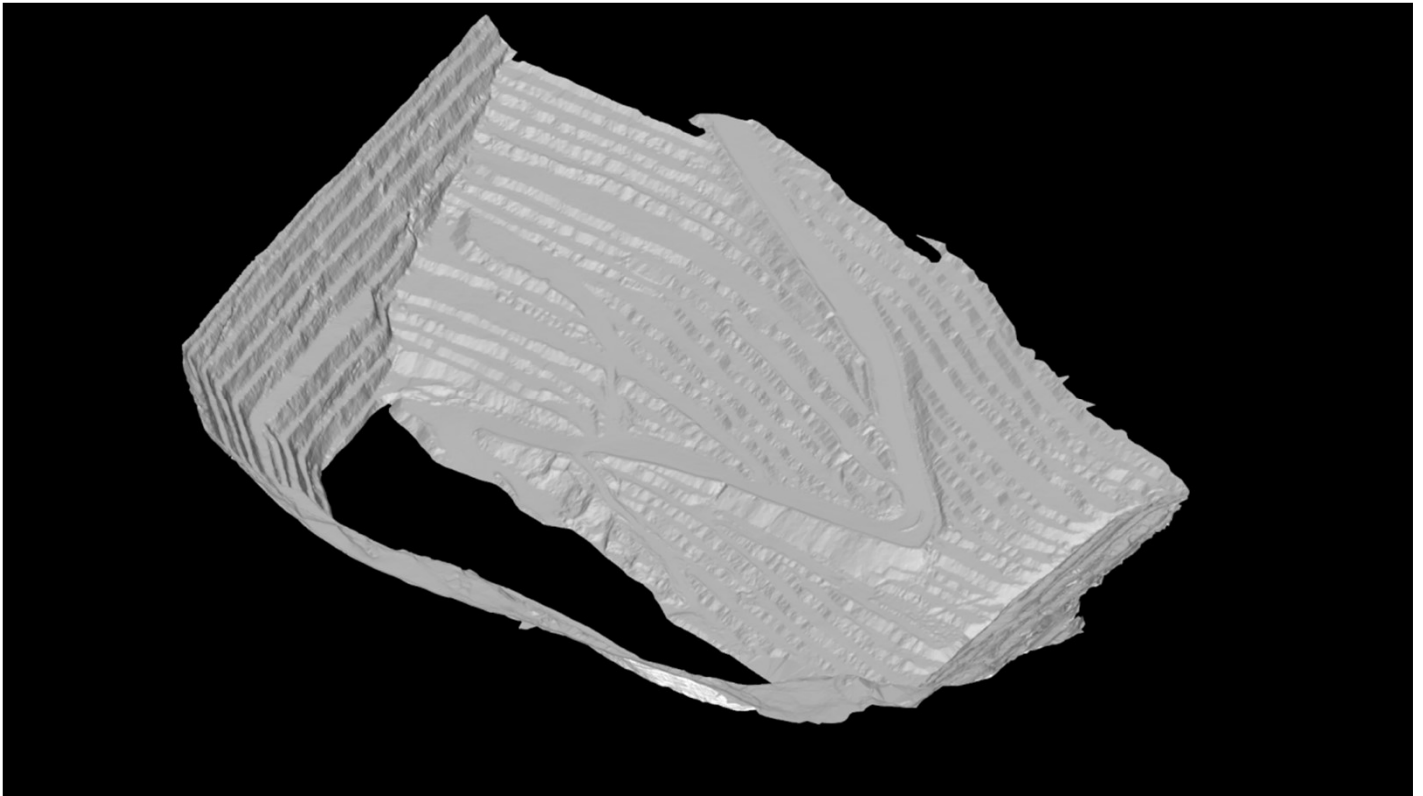

Surveyors have been using LiDAR for many years.

Benefits include:

Safety

Detail

Remote survey

Accuracy

## Types of scanners



Although LiDAR is a term used to describe the measurement technique there are several distinctly different ways that measurements are made.

These can be used to group laser scanners into separate categories, each with particular advantages and limitations.

## Structured light principle



Structured light or light shadow principle is used in hand-held laser scanners.

These are typically limited in range up to about 5m.

These systems can be low-cost but also highly accurate.

The most common example of structured light scanners is actually the Xbox Kinect, which captures users' body positions in real-time and enables them to interact directly with games.

There is a lot of interest in this field, including by Google who hold patents on devices small enough to be built into mobile phones.

## Structured light applications



Structured light scanners are most commonly used in the fields of industrial design, archaeology, and forensics.

## Phase scanner principle

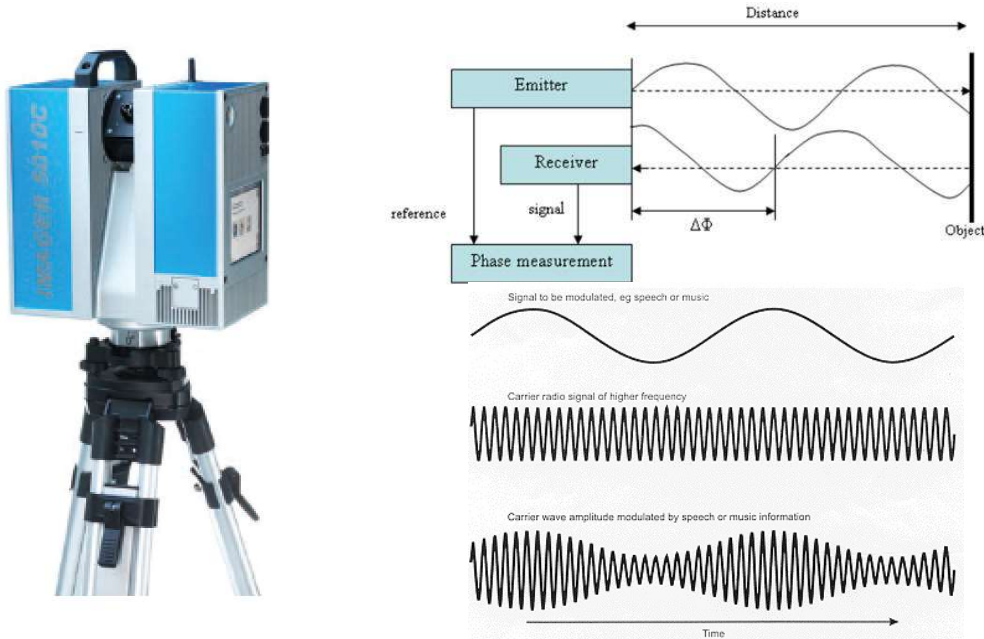

Phase based scanners measure distance using a continuous laser beam. Wave theory in physics teaches that a waveform will invert when it meets a rigid barrier. Phase scanners measure the inversion point to determine the distance travelled.

Phase scanners operate at very high speeds due to not needing to switch the laser on and off; typically measuring 1 million points per second.

Phase scanners also operate at very high accuracy but have limited range. The range limitation is equal to the wavelength of the "carrier frequency", sometimes referred to as the disambiguity interval.



## Phase scanner applications - Forensics



The highly detailed scans from phase scanners are ideally suited to crime scene investigation.

## Forensics (blood spatter – origin of impact; statement testing; weapons testing)

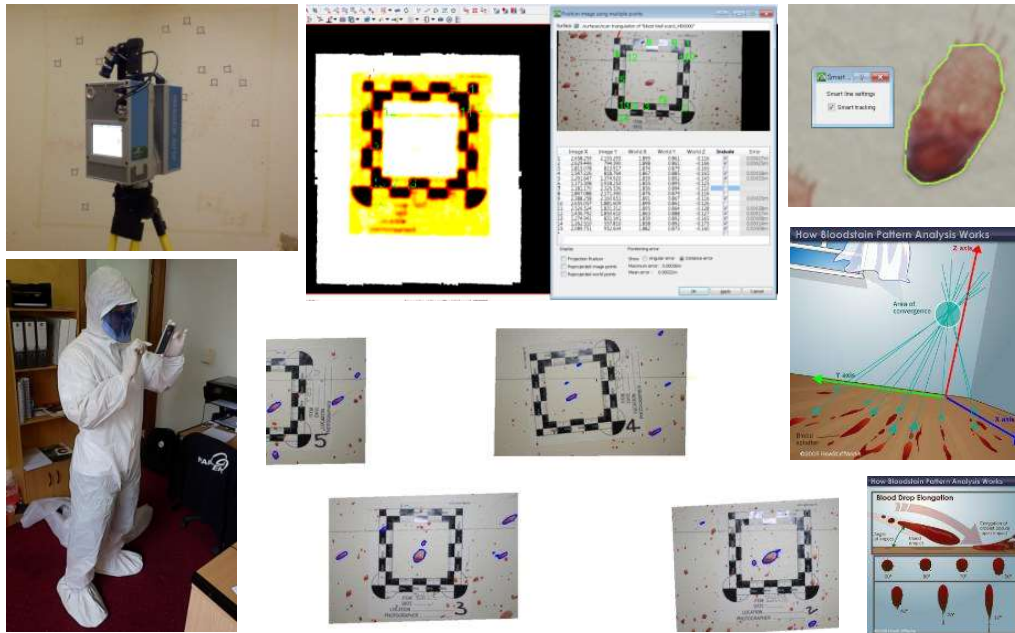

Specialist applications such as blood spatter analysis can be completed in the digital context rather than using traditional manual techniques.

The data is preserved for future reference if any questions later arise.

**Forensics** (accident investigation, collision paths, deformation analysis, statement testing, prevent tampering)

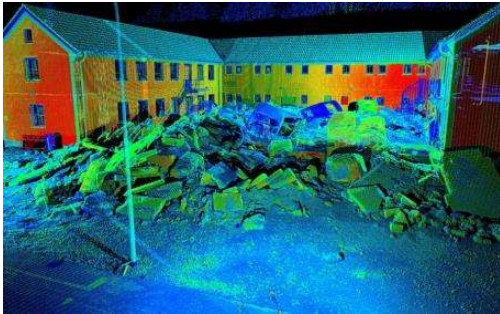

Vehicle accident and natural disaster emergencies are ideal applications for LIDAR. Investigations are later helped by data captured quickly after critical incidents but the first priority must always be on rescue and recovery. LIDAR enables efficient and detailed data capture without impeding the work of emergency services.

**Mechanical Asbuilts - Wear detection, Reverse Engineering, Design vs Asbuilt (Engineering scanners)**

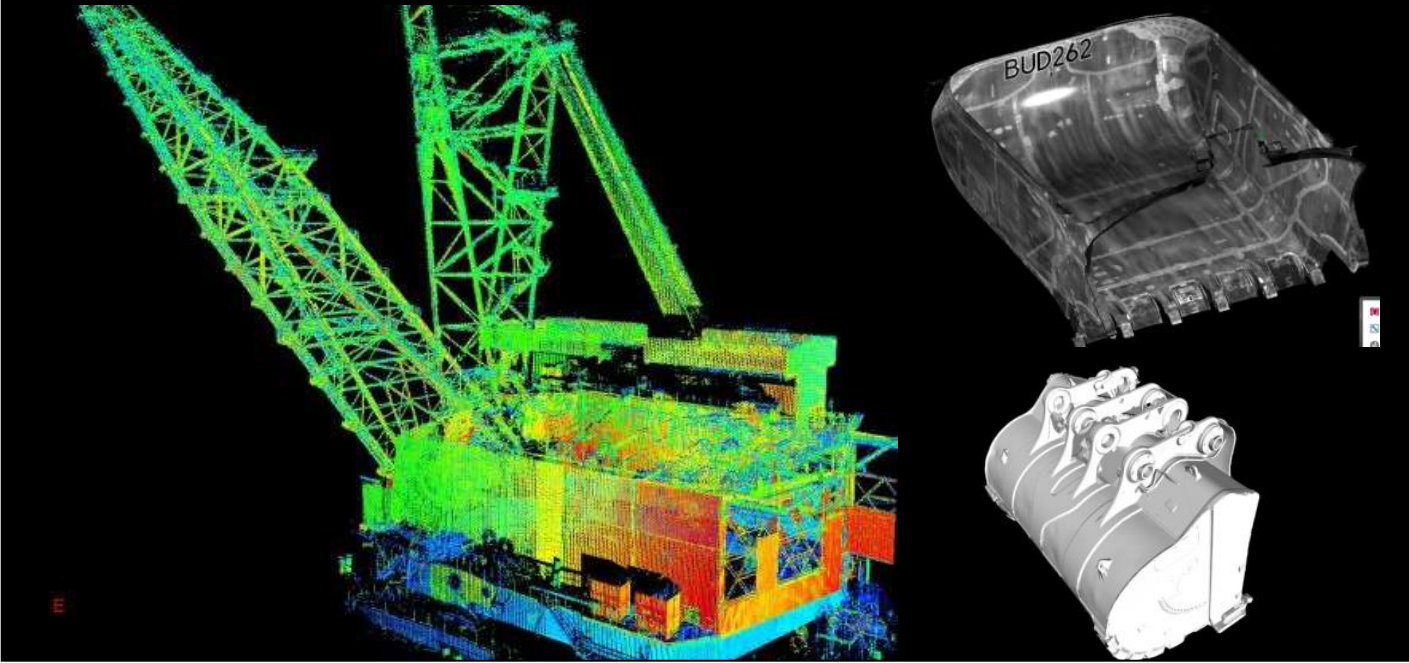

# Civil Asbuilts (road works, drainage, tunnels, etc) (Engineering scanners)



- Scanning for civil works.
- Check Asbuilt against design.
- Ensure crossfall and grades within design tolerance, etc.
- Check line work and kerb positioning, etc.
- Acquire data for future analysis on surface degradation (for contract warranty)

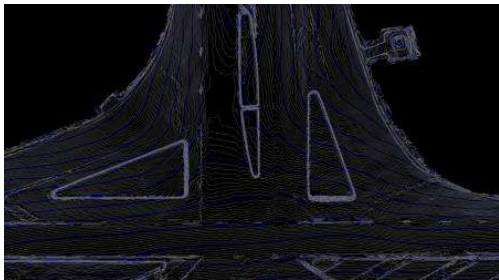
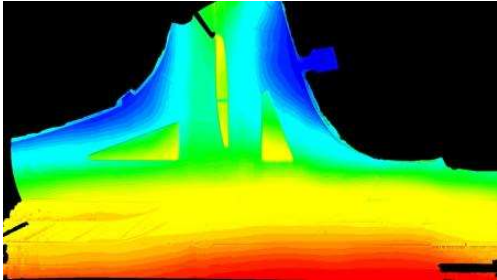

# Infrastructure modeling (Engineering scanners)

(e.g. for old plants with no plans; building structural measurements, etc)

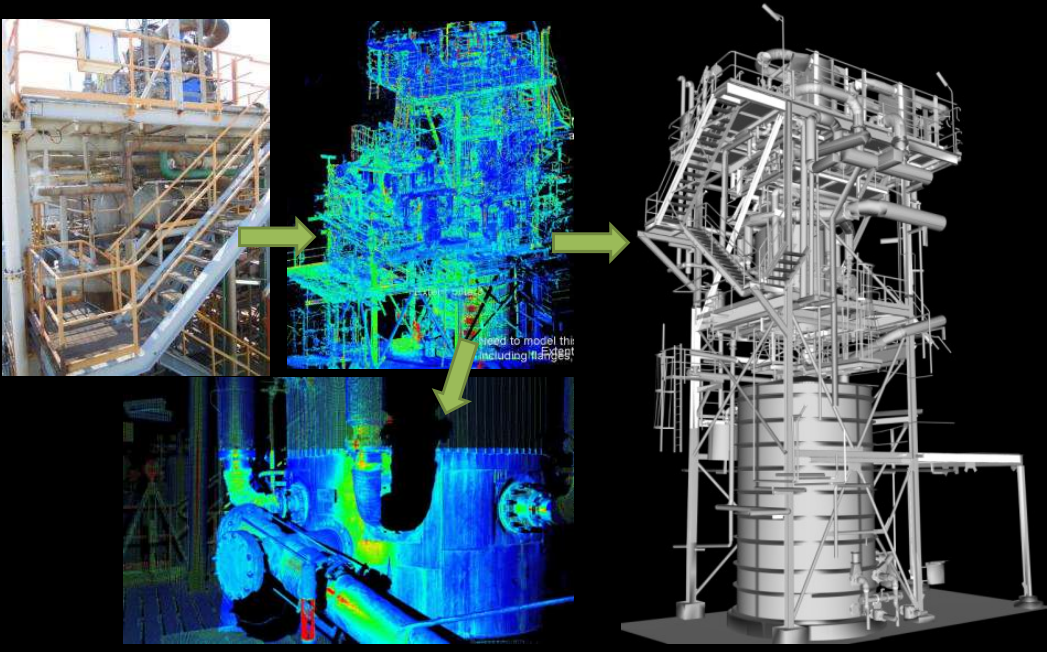

## Preserving history

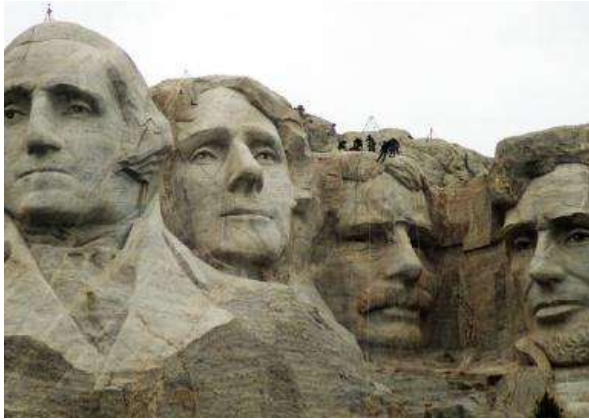

Mt Rushmore, source:  
[archive.cyark.org](http://archive.cyark.org)

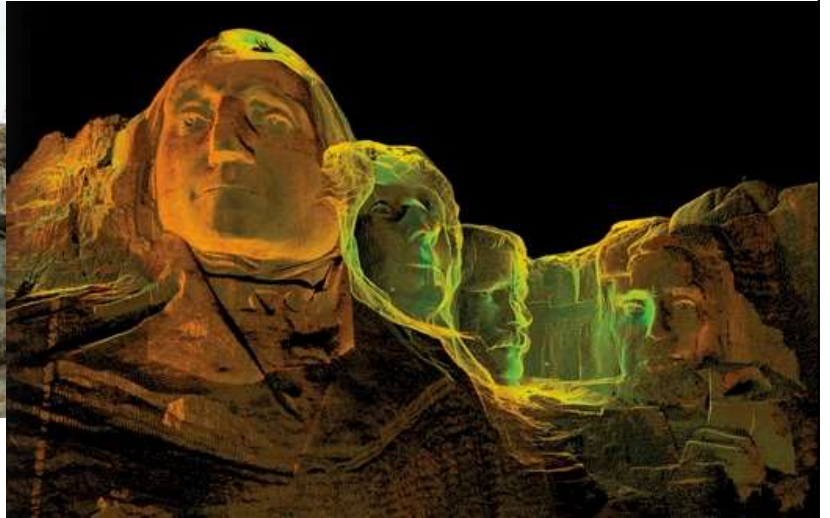

Scottish 10 sites:

New Lanark

Neolithic Orkney

St Kilda

Edinburgh

Antonine Wall

Mount Rushmore

Rani ki Vav, India

Eastern Qing Tombs, China

Sydney Opera House, Australia

Nagasaki, Japan

<https://www.enginshed.scot/about-us/the-scottish-ten/>

## Time of flight principle

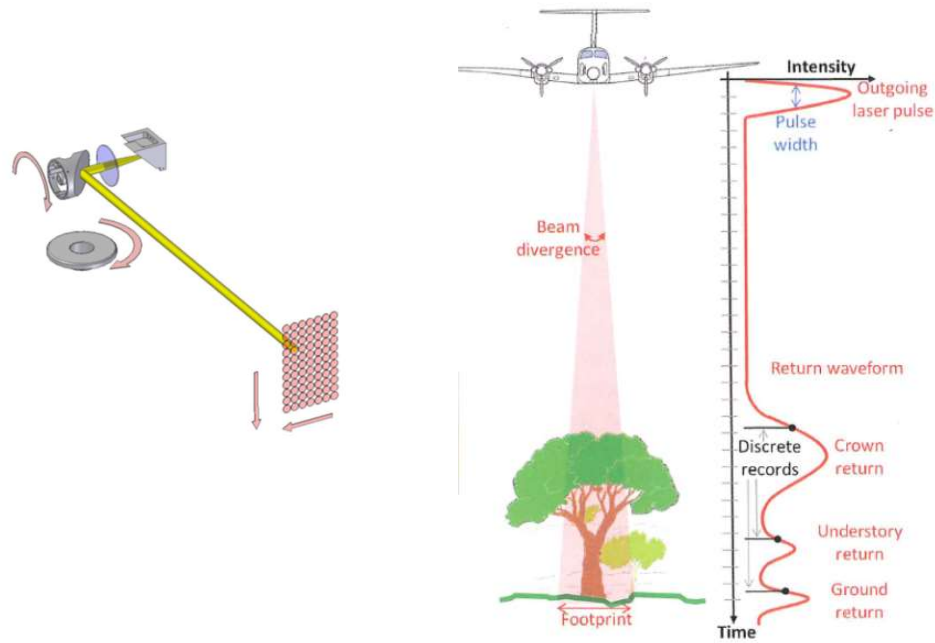

Time of flight measurement is typically used in applications where the range of measurement is most important.

The laser is switched on and off rapidly to create “pulses” of light, typically 3 nanoseconds in length.

The time taken for the pulse to return to the instrument is measured and the distance calculated.

Pulse based systems typically have lower speed than phased based but have much longer range and better penetration of line-of-sight obstructions (fog, dust, vegetation, etc)





Source: [www.pobonline.com](http://www.pobonline.com)

Airborne LIDAR systems have been in use for decades but in recent years remotely piloted and autonomous airborne vehicles (drones) are becoming common.

These rely on light-weight sensors such as the Velodyne puck shown in the image.

These sensors have been primarily developed for navigation of autonomous vehicles.

They offer excellent data capture in inaccessible areas, complementing ground-based solutions, but care should be taken to ensure the accuracy of measurements is fit for purpose.

For more information on the accuracy considerations of light-weight airborne systems see the article here:

<http://geoawesomeness.com/accurate-drone-survey-everything-need-know/>

## How to pick the right system?

- Accuracy required
- Level of detail required
- Access limitations
- Distance required
- End result and deliverables



The range of systems available increases every year so how do you select the right system for your job?

Consider the specific requirements and ensure you know what you want from the data.

Laser scanners capture highly detailed point-clouds, but these are not a result in themselves.

Ensure the instrument or service provider has the software to extract meaningful results from the data.

# Case study 1: underground mapping

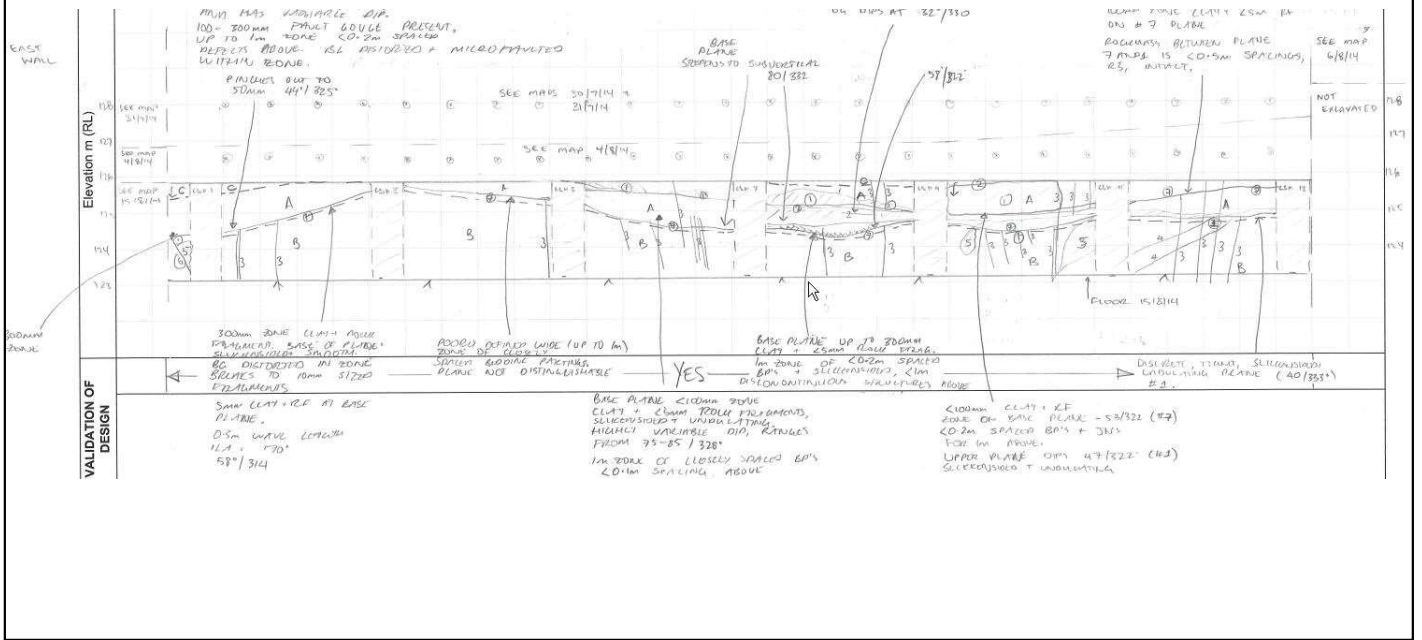

Geological and structural mapping is commonly completed manually on paper. Laser scanning is an excellent tool to convert this to a digital process, enabling mapping in inaccessible areas and removing geospatial uncertainty.

## Case study 1: underground mapping

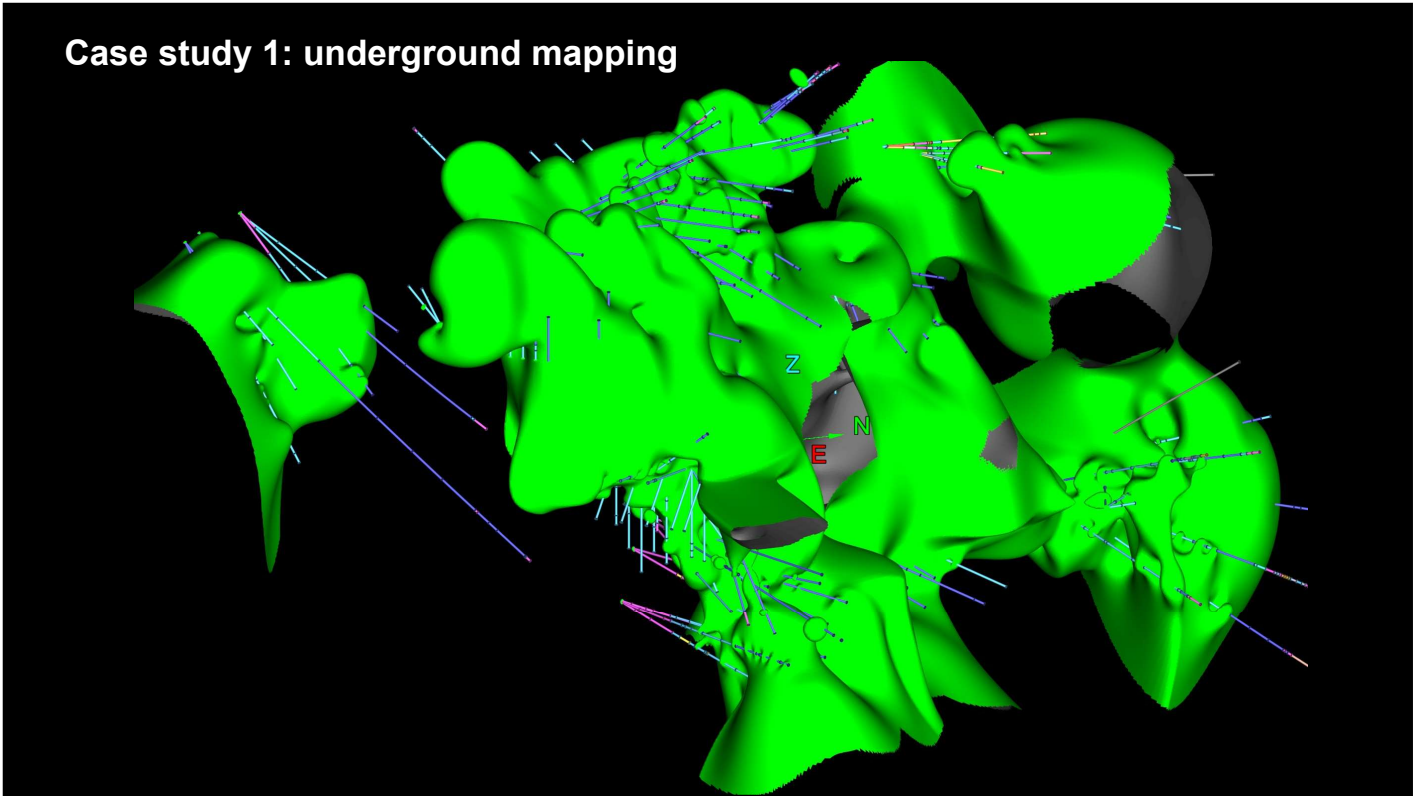

Complex geology can be more accurately mapped using digital techniques

## Case study 1: underground mapping

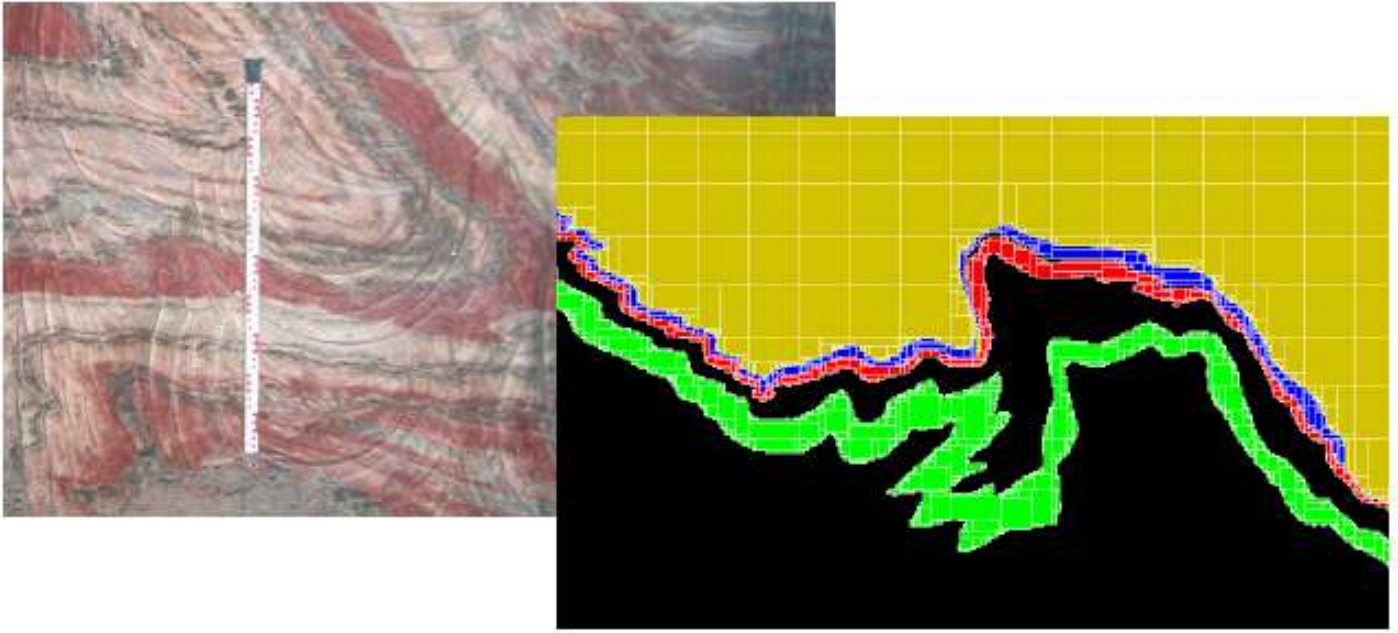

This example shows a heavily folded deposit mapped using LIDAR

## Case study 1: underground mapping

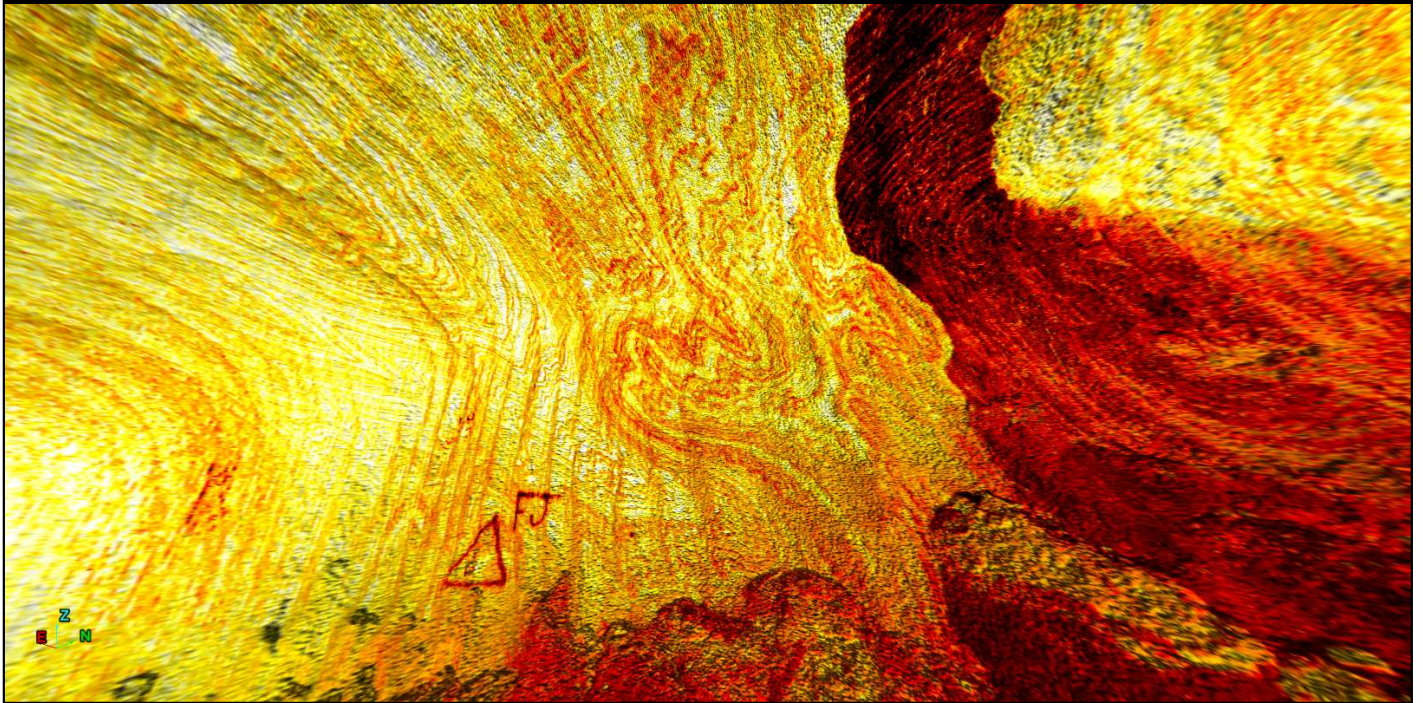

LIDAR systems capture more than just the position of a point.

This image shows a point cloud coloured by the intensity or reflectivity of the return.

Different materials will reflect more or less laser power and this can be used to highlight geological boundaries.

Comparing the photographic image with the intensity map can give confidence in identified geological contacts.

Additional comparisons can be gained using hyperspectral imaging and other techniques.

## Case study 2: structural mapping



High resolution imagery is commonly overlaid on LIDAR data.

## Case study 2: structural mapping

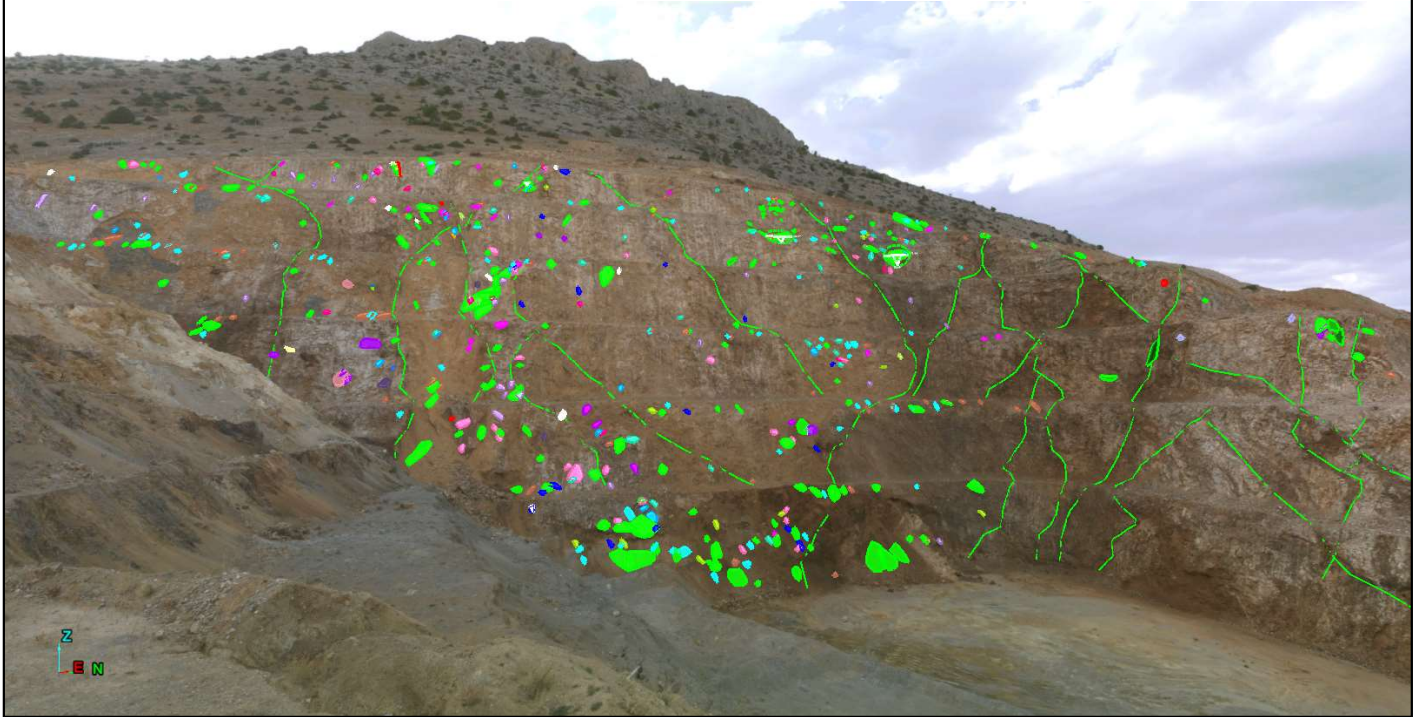

Overlaying a photograph on LIDAR data assists with mapping of structural planes in addition to geological features.



## Limitations

- Survey support required
- Not all mineralisation will be readily identifiable
- Time constraints
- Accuracy degrades with distance

It is important to remember that lasers used in LIDAR systems diverge over distance.

This degrades accuracy and limits the detail that can be captured at long ranges.

## Conclusion

- Good design relies on good information
- LiDAR provides reliable and accurate geospatial information
- Design compliance and effectiveness can be actively monitored
- LiDAR: not just for surveyors





[www.maptek.com](http://www.maptek.com)